

BOILER-M8[®]

A-RATED

EEI ≤ 0.20

ErP
READY 

High Efficiency Circulator Pump Installation & Operating Manual

**WARNING**

Prior to installation, please read these installation and operating instructions carefully. The product warranty requires the installation and commissioning of Boiler-m8 circulating pumps to be carried out by a qualified installer in compliance with BS 7593:2019 and all local building regulations and accepted codes of practice in force at the time of installation.

Failure to follow the correct installation or use of the product for any purpose outside of the manufacturers intended design will invalidate the product warranty.

Contents

1. General Information	2
2. Application	2
2.1 Advantages	3
3. Pump Liquid	3
4. Product Key (Fig.1)	4
4.1 Understanding the Model Code	5
5. Control Panel	5
5.1 Pump Setting Indicators	5
5.2 Push-button for selection of Pump Setting	5
5.3 Error Codes	5
5.4 Functions on the Control Panel	6
6. Performance Drawing	7
7. Fault Finding Chart	9
8. Installation	10
9. Warranty Registration	15

Version 3.3 Issue Date: 21st February 2023

©Boiler-M8 2023 ALL RIGHTS RESERVED

E&OE



1. General Information

These operating instructions explain the main functions and operation of the pump when installed and ready for use. The installation must be completed by a qualified engineer in accordance with BS 7593:2019

Description: Boiler-m8 RS25-6/EAZ 'A' Rated Central Heating Circulating Pump

SKU: 155-0020

EAN: 5060797371085

2. Application

Boiler-m8 ERp low-energy circulation pumps are designed for the circulation of water in heating systems that are installed, commissioned and operated to BS 7593:2019.

This product is suitable for domestic:

- Underfloor heating systems
- One-pipe systems
- Two-pipe systems

All Boiler-m8 ERp High Efficiency circulating pumps are 'A' rated



2.1 Advantages of installing a Boiler-m8 ERp High Efficiency circulating pump

Easy Installation & Quick Commissioning

- Boiler-m8 circulation pumps are easy to install.
With the default factory 'AUTO' setting, the pump can, in most cases be started without any further adjustment

High Degree of Comfort

- Minimum noise from valves and pipework

Low Energy Consumption

- Low energy consumption compared to the conventional circulation pumps

3. Pump Liquid

Boiler-m8 circulating pumps are designed for heating system liquid treated in compliance with BS 7593:2019

Using the pump to circulate mineral oils, fibrous fluids with particles, or aggressive/explosive liquids will invalidate the product warranty and may cause serious injury.



4. Product Key (Fig.1)

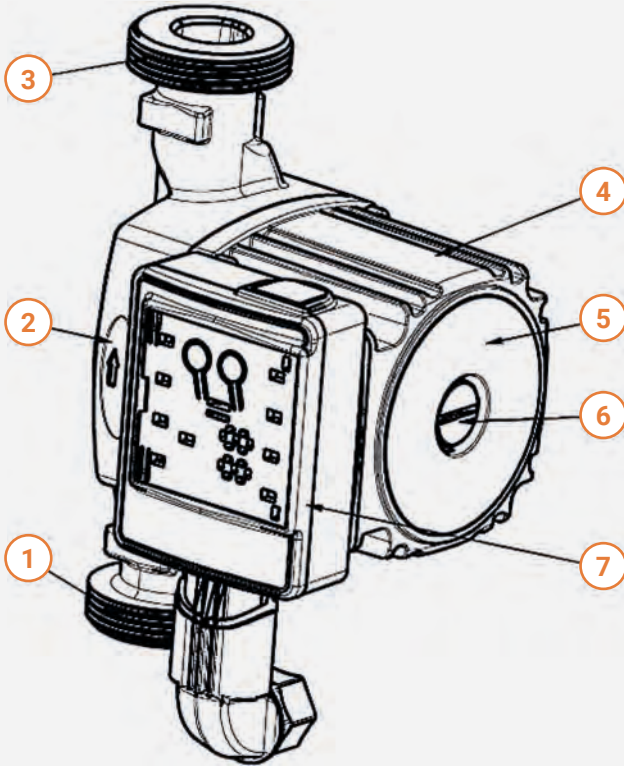

1.	Inlet	4.	Motor Housing	7.	Control Panel
2.	Base/Impeller Housing	5.	Model Rating Label		
3.	Outlet	6.	Air Vent		

BOILER-M8

4.1 Understanding the Model Code



5. Control Panel

5.1 Pump Setting Indicators

Boiler-m8 ERp High Efficiency circulating pumps have multiple settings which can be selected with the push-buttons '7' and '8' as described in the following table.

The current setting is indicated by one of the nine different light indicators, as detailed in the following table.

5.2 Push-button for selection of Pump Setting

Each time the push-button is pressed, the pump setting is changed. Once the desired indicator is lit, the pump is set.

As all heating systems are different (especially older systems), you may need to try various settings during commissioning to find the optimal performance for your heating system.

5.3 Error Codes

- E1: Motor and/or impeller obstruction, please open the pump head and remove debris
- E2: Electrical wiring fault: Check the connections and PCB for damage or water ingress
- E3: High temperature protection – check pump for air and ensure impeller shaft position is horizontal – vent pump and restart once cooled
- E4: IPM error, hardware fault, replacement PCB required
- E5: Electrical over current
- E6: Accumulated more than 5 fault warnings in a given period. Power off and check the pump, re-start once complete.



5.4 Functions on the Control Panel

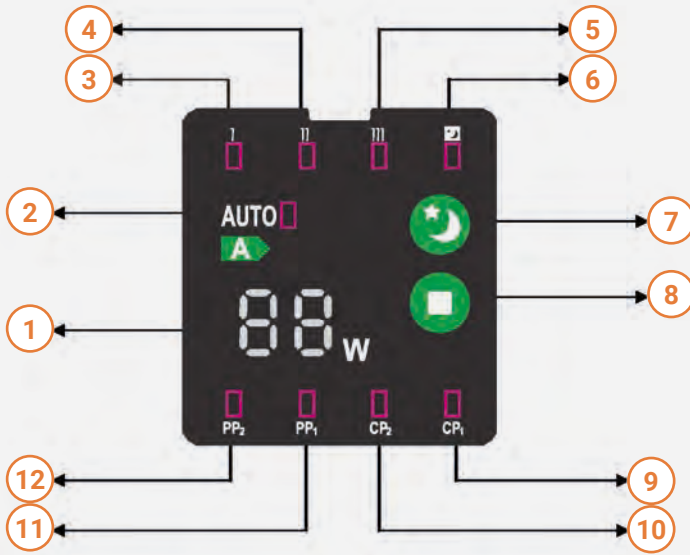

1.	Actual working power display	8.	Push-button for selection of pump setting
2.	Light field indicating AUTO mode	9.	CP1 indicating Min constant pressure curve
3.	Min speed for manual button	10.	CP2 indicating Max constant pressure curve
4.	Mid speed for manual button	11.	PP1 indicating Min proportion pressure curve
5.	Max speed for manual button	12.	PP2 indicating Max proportion pressure curve
6.	Light fields indicating night mode		
7.	Push-button to select night mode		

BOILER-M8

6. Relation between Pump Setting and Pump Performance

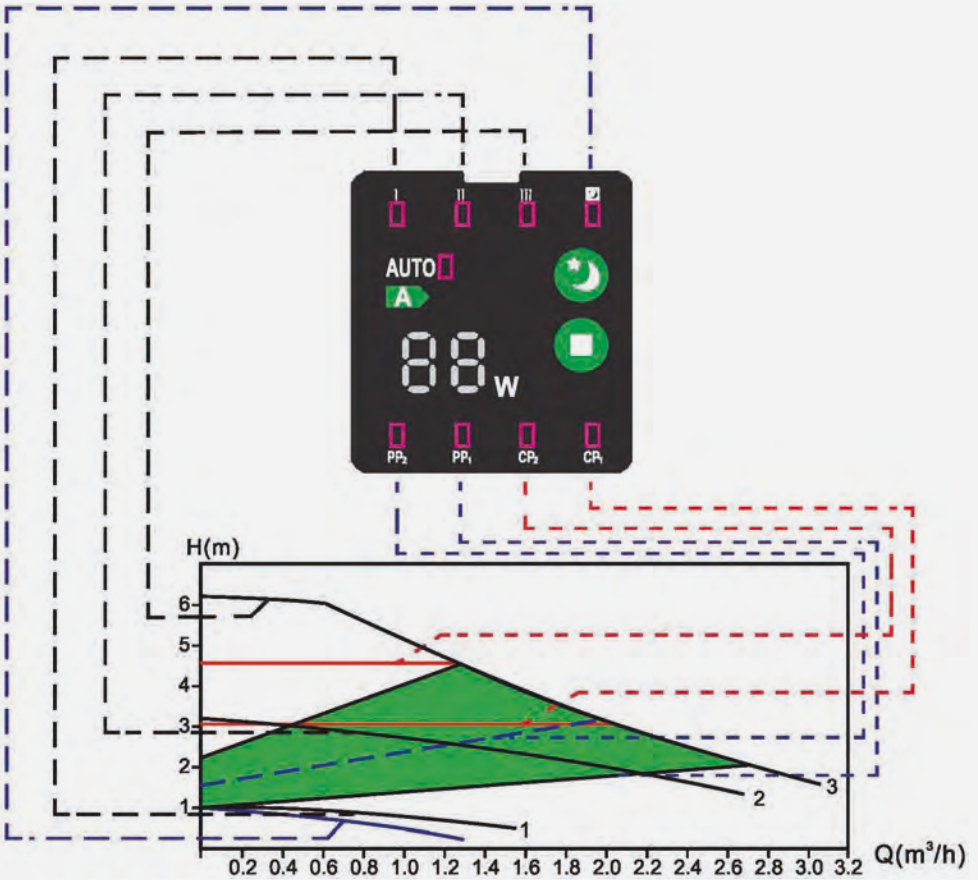

Setting	Pump Curve	Function
PP1	Lowest proportional Pressure curve	The performance of the pump will move up or down on the lowest proportional-pressure curve, depending on heating demand. The head (pressure) is reduced at falling heating demand and increased at rising heating demand.
PP2	Highest proportional Pressure curve	The performance of the pump will move up or down on the highest proportional-pressure curve, depending on the heating demand. The head (pressure) is reduced at falling heating demand and increased at rising heating demand.
CP1	Lowest constant Pressure curve	The performance of the pump will move out or in constant-pressure curve, depending on the heating demand. The head (pressure) is kept constant, irrespective of the heating demand.
CP2	Highest constant Pressure curve	The performance of the pump will move out or in constant-pressure curve, depending on the heating demand. The head (pressure) is kept constant, irrespective of the heating demand.
III	Speed III	Pump runs at a constant speed and consequently on a constant curve. In speed III. the pump is set to run on max performance curve under all operating conditions. Quick venting of the pump can be obtained by setting the pump to speed III for a short period.
II	Speed II	Pump runs at a constant speed and consequently on a constant curve. In speed II, the pump is set to run on the medium curve under all operating conditions.
I	Speed I	Pump runs at a constant speed and consequently on a constant curve. In speed I, the pump is set to run on the min. curve under all operating conditions.
AUTO Ex-factory setting		Under "AUTO" mode, the power of pump is automatically modulated up or down according to the system requirements.
	Night Mode	If night mode is selected, after one hour the power is automatically reduced, after two hours it will be reduced to the lowest setting (between 5 - 10watts). After seven hours, the pump will recover to its original setting



7. Fault Finding Chart



WARNING

Only a qualified engineer should undertake inspection of the pump. Before removing the cover or starting any work on the pump, you must make sure that the electricity supply has been switched off and that it cannot be accidentally switched on.

Fault	Control Panel	Cause	Remedy
1. The pump does not run	All control panel lights off.	a) Fuse in the installation is blown.	Replace the fuse.
		b) The current-operated or voltage-operated circuit breaker has tripped out.	Reset the circuit breaker and check.
		c) The pump is defective.	Replace the pump.
	Only show power.	a) Electricity supply failure. May be too low.	Check that the electricity falls within the specified range.
		b) The pump is blocked.	Remove the blockage.
2. Noise in the System	Power and light indicators for pump settings are on.	a) Air in the system.	Vent the system.
		b) The flow is too high.	Reduce the setting.
3. Noise in the Pump.	Power and light indicators for pump settings are on.	a) Air in pump.	Leave the pump to run, it vents itself over time. (increase power to maximum to speed up the elimination of air.)
		b) The system pressure is too low.	Increase the system pressure and check the expansion tank if installed.
4. Insufficient Flow	Power and light indicators for pump settings are on.	a) The pump performance is too low.	Increase the setting.

Error code table is shown at 5.3



8. Installation

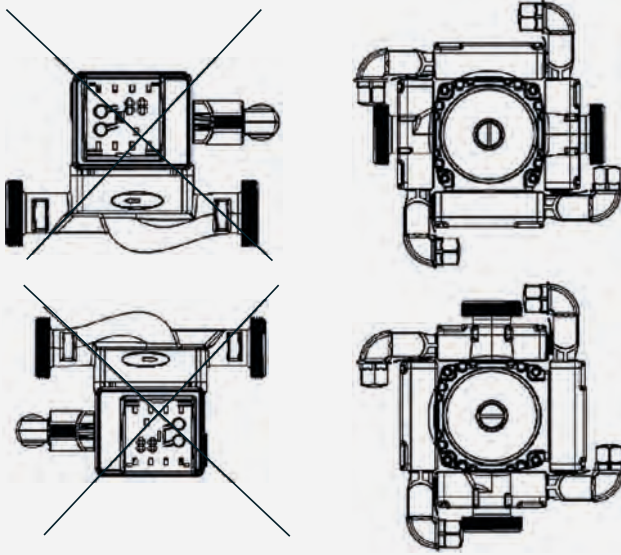

Attention: The pump MUST be installed with the motor shaft in the horizontal position to prevent air from collecting within the pump head.

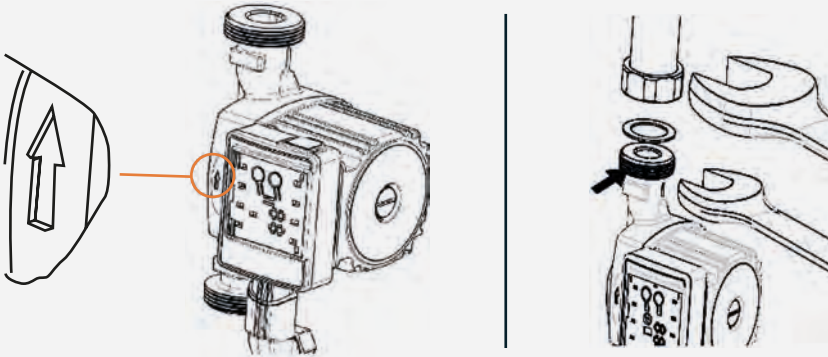

BOILER-M8

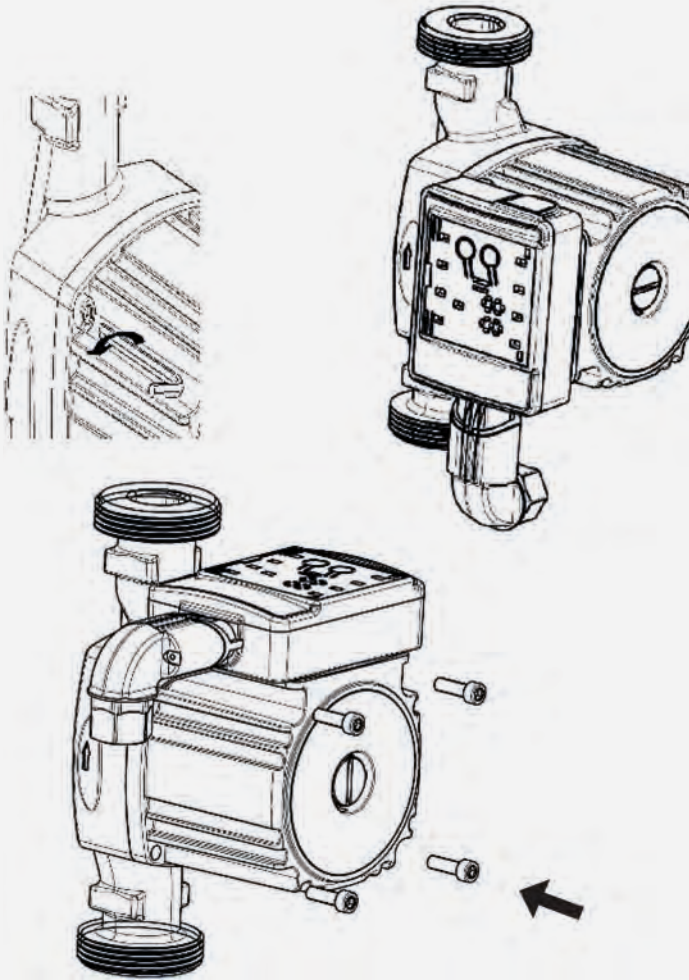

The system liquid may be scalding hot and under the high pressure. Drain the system or close the isolating valves on either side of the pump before removing the pump or pump head.

BOILER-M8

Be careful to ensure that the direction of flow indicator on the pump body is in the correct position for your system

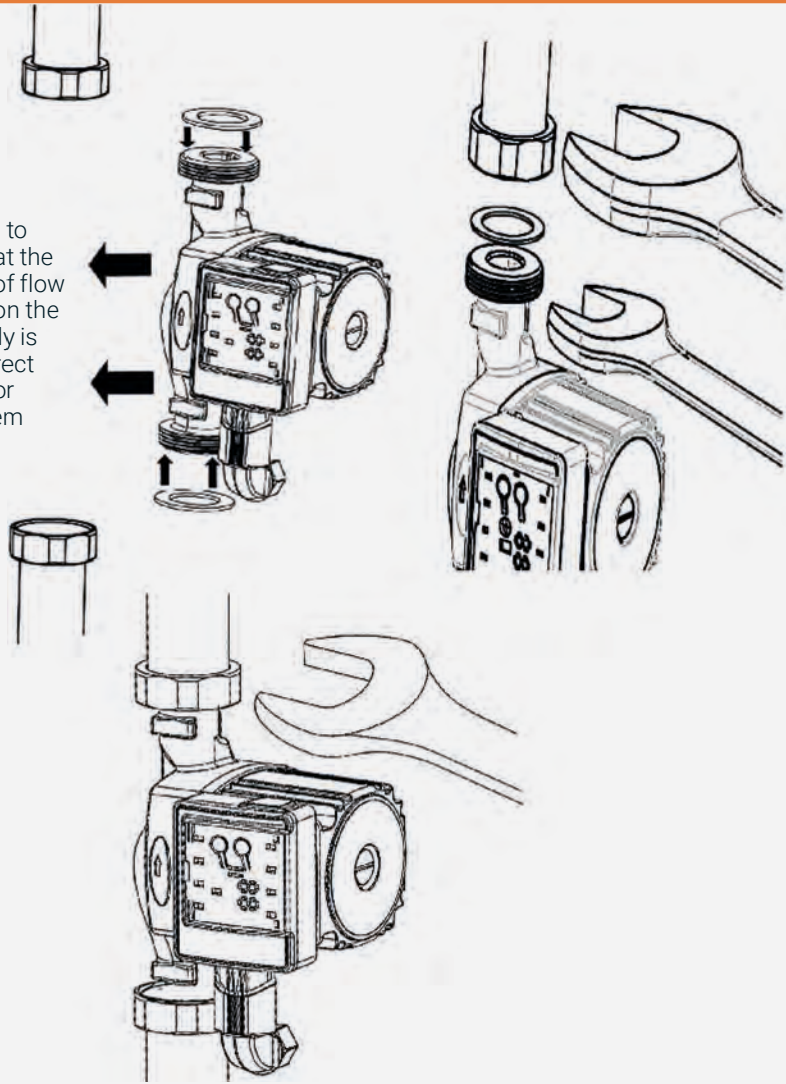

Attention: Fit the two seals between the pump and the pump valves.

BOILER-M8

www.boiler-m8.com
sales@boiler-m8.com
0333 305 8210

Boiler-m8®
Suite 11 Peel House, 30 The Downs,
Altrincham, Cheshire WA14 2PX

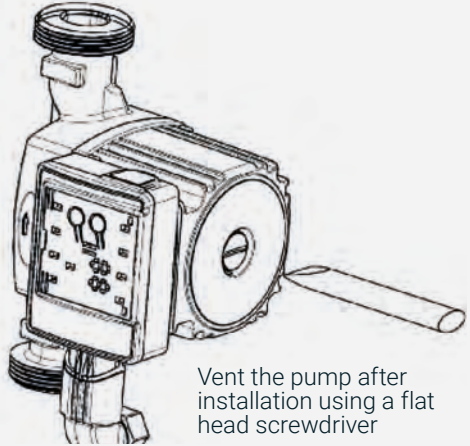
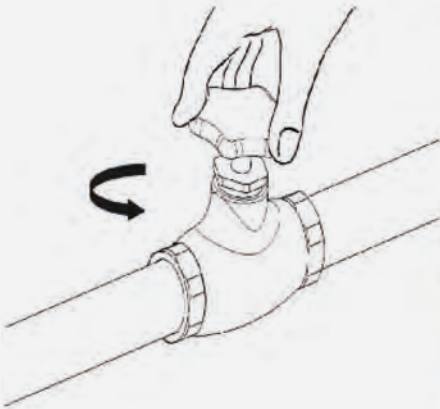
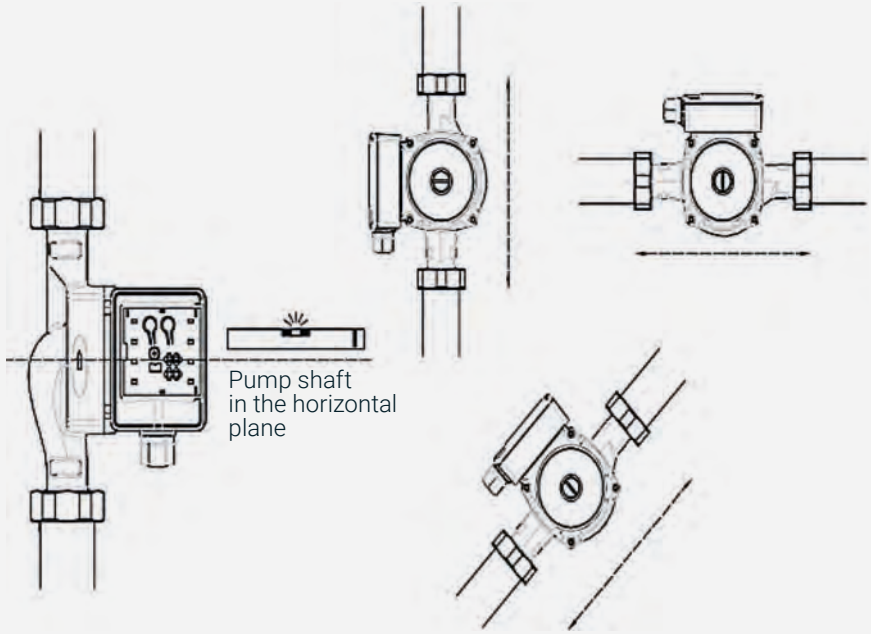

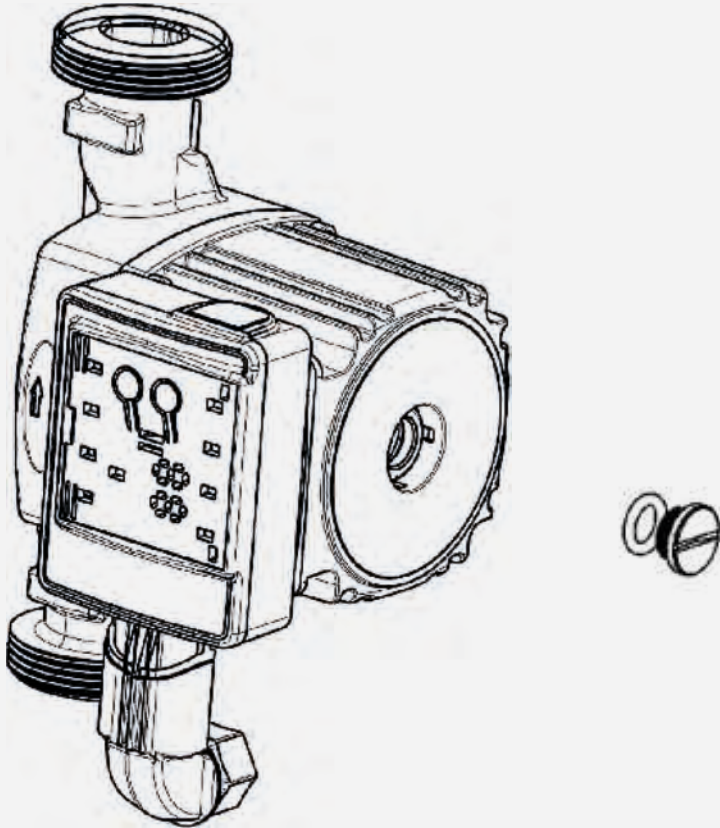

WARNING

Venting the pump, please take care as the liquid may be very hot.

Attention: The pump must not be allowed to run dry.



9. Warranty Registration

Register your warranty at:



Or visit:

<https://boiler-m8.com/warranty-registration>



Try our other products:



Boiler-m8 Defender-2 Magnetic Boiler System Filter 22mm

- High strength magnet
- Built in drain off port with hose connection
- Manufactured from PA66 Polymer
- Brass Diverter and Full Bore Brass Isolating Valves



Boiler-m8 System Health Inhibitor Concentrate 500ml

- Buildcert NSF Benchmark Approved
- WRAs Approved



The New AirMaster™ For Your Heating System

- Full-bore design
- Automatic air separation and venting
- Brass body
- 360° Diverter
- Compression connections



BOILER-M8

A stylized flame icon with a blue and orange gradient, positioned to the right of the 'BOILER-M8' text.

**FOLLOW US ON SOCIAL MEDIA
/BOILERM8**